



**Technical and Test Institute  
for Construction Prague**

Prosecká 811/76a  
190 00 Prague  
Czech Republic  
eota@tzus.cz

Member of



www.eota.eu

## European Technical Assessment

**ETA 08/0267  
of 25/07/2017**

(English language translation, the original version in Czech language)

**Technical Assessment Body issuing the  
ETA**

Technical and Test Institute  
for Construction Prague

**Trade name of the construction product**

BRAVOLL® PTH-S, RS-H, RS-Z

**Product family to which the construction  
product belongs**

Product area code: 33  
Plastic anchors for fixing of external  
thermal insulation composite systems with  
rendering in concrete and masonry

**Manufacturer**

ITW Construction Products CZ s.r.o.  
Sídliště 696  
394 68 Žirovnice  
Czech Republic

**Manufacturing plant(s)**

ITW Construction Products CZ s.r.o.

**This European Technical Assessment  
contains**

21 pages including 17 Annexes which form  
an integral part of this assessment.

**This European Technical Assessment is  
issued in accordance with regulation  
(EU) No 305/2011, on the basis of**

EAD 330196-00-0604

**This version replaces**

ETA 08/0267 issued on 10/03/2017

Translations of this European Technical Assessment in other languages shall fully correspond to the original issued document and should be identified as such.

Communication of this European Technical Assessment, including transmission by electronic means, shall be in full (excepted the confidential Annex(es) referred to above). However, partial reproduction may be made, with the written consent of the issuing Technical Assessment Body - Technical and Test Institute for Construction Prague. Any partial reproduction has to be identified as such.

## 1. Technical description of the product

The anchors BRAVOLL® PTH-S consist of a plastic sleeve with a plate and an accompanying specific expansion screw for fixing for thermal insulation system (ETICS).

The plastic sleeve of anchor BRAVOLL® PTH-S is made of polypropylene and an accompanying specific expansion screw is made of steel strength class 5.8 or stainless steel. The head of the specific expansion screw has a plastic coating made of reinforced polyamide.

The anchors BRAVOLL® PTH-S for a surface assembly may additionally be combined with assembling tools BRAVOLL® MPS which are shown in Annex A7 and with the additive anchor plates BRAVOLL® IT PTH 100 and IT PTH 140, which are shown in Annex A8.

The countersunk assembly may additionally be combined with assembling tools BRAVOLL® ZP, BRAVOLL® MPS, BRAVOLL® ZPS, BRAVOLL® ZPR and with Insulation covers IZ which are shown in Annex A6-A7 and plates BRAVOLL® ZT 100, ZT 120 see Annex A9 with Insulation covers IZ which are shown in Annex A6.

The installed anchor BRAVOLL® PTH-S is shown in Annex A1-A3

BRAVOLL® RS-H and BRAVOLL® RS-Z are the screwed-in plastic frame anchors, which consist of a plastic sleeve with a collar made of polypropylene and an accompanying specific expansion screw made of steel strength class 5.8. The anchors are for fixing the profiles for thermal insulation system (ETICS).

The installed anchor BRAVOLL® RS-H is shown in Annex A4 .

## 2. Specification of the intended use in accordance with the applicable EAD

The performances given in Section 3 are only valid if the anchor is used in compliance with the specifications and conditions given in Annex B1-B6.

The provisions made in this European Technical Assessment are based on an assumed working life of the anchor of 25 years. The indications given on the working life cannot be interpreted as a guarantee given by the producer, but are to be regarded only as a means for choosing the products in relation to the expected economically reasonable working life of the works.

## 3. Performance of the product and references to the methods used for its assessment

### 3.1 Mechanical resistance and stability (BWR 1)

Essential characteristic	Performance
Characteristic resistance for tension loads	See Annex C 1
Displacement	See Annex C 1
Point thermal transmittance	See Annex C 2
Plate stiffness	See Annex C 2

### 3.2 Safety in case of fire (BWR 2)

ETAG 004 is relevant.

### 3.3 Hygiene, health and environment (BWR 3)

Regarding dangerous substances contained in this European Technical Assessment, there may be requirements applicable to the products falling within its scope (e.g. transposed European legislation and national laws, regulations and administrative provisions). In order to meet the provisions of the Regulation (EU) No 305/2011, these requirements need also to be complied with, when and where they apply.

### 3.4 Safety in use (BWR 4)

For basic requirement safety in use the same criteria are valid as for Basic Requirement Mechanical resistance and stability.

### 3.5 Protection against noise (BWR 5)

Not relevant.

### 3.6 Energy economy and heat retention (BWR 6)

Not relevant.

### 3.7 Sustainable use of natural resources (BWR 7)

For the sustainable use of natural resources no performance was determined for this product.

### 3.8 General aspects relating to fitness for use

Durability and serviceability are only ensured if the specifications of intended use according to Annex B 1 are kept.

## 4. Assessment and verification of constancy of performance (AVCP) system applied with reference to its legal base

According to the Decision 97/463/EC of the European Commission<sup>1</sup>, the system of assessment verification of constancy of performance (see Annex V to the Regulation (EU) No 305/2011 given in the following table apply:

Product	Intended use	Use category	System
The plastic anchors PTH-S for fixing of external thermal insulation composite systems with rendering	For fixing of external thermal insulation composite systems with rendering	A, B, C, D and E.	2+
The plastic anchors RS-H a RS-Z for fixing the profiles for thermal insulation system (ETICS).	For fixing of external thermal insulation composite systems with rendering	A, B, C, D and E.	2+

## 5. Technical details necessary for the implementation of the AVCP system, as provided in the applicable EAD

### 5.1 Tasks of the manufacturer

The manufacturer shall exercise permanent internal control of production. All the elements, requirements and provisions adopted by the manufacturer shall be documented in a systematic manner in the form of written policies and procedures, including records of results performed. This production control system shall insure that the product is in conformity with this European Technical Assessment.

The manufacturer may only use raw materials stated in the technical documentation of this European Technical Assessment.

<sup>1</sup> Official Journal of the European Communities L 198/31 25.7.1997

The factory production control shall be in accordance with the control plan which is a part of the technical documentation of this European Technical Assessment. The control plan is laid down in the context of the factory production control system operated by the manufacturer and deposited at Technical and Test Institute for Construction Prague.<sup>2</sup> The results of factory production control shall be recorded and evaluated in accordance with the provisions of the control plan.

The manufacturer shall, on the basis of a contract, involve a body which is notified for the tasks referred to in section 4 in the field of anchors in order to undertake the actions laid down in section 5.2. For this purpose, the control plan referred to in this section and section 5.2 shall be handed over by the manufacturer to the notified body involved.

The manufacturer shall make a declaration of performance, stating that the construction product is in conformity with the provisions of this European Technical Assessment.

## 5.2 Tasks of the notified bodies

The notified body shall retain the essential points of its actions referred to above and state the results obtained and conclusions drawn in a written report.

The notified certification body involved by the manufacturer shall issue a certificate of constancy of performance of the product stating the conformity with the provisions of this European Technical Assessment.

In cases where the provisions of the European Technical Assessment and its control plan are no longer fulfilled the notified body shall withdraw the certificate of constancy of performance and inform Technical and Test Institute for Construction Prague without delay.

Issued in Prague on 25.07.2017



By

**Ing. Mária Schaan**

Head of the Technical Assessment Body

---

<sup>2</sup> The control plan is a confidential part of the documentation of the European Technical Assessment, but not published together with the ETA and only handed over to the approved body involved in the procedure of AVCP.

### Surface assembly for fixing of ETICS in categories A, B, C and D

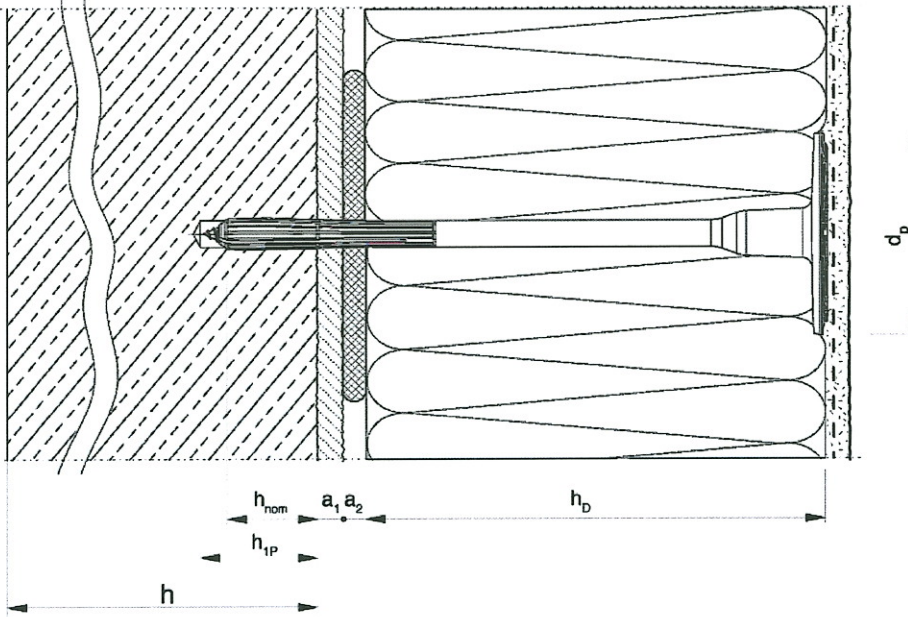

### Countersunk assembly for fixing of ETICS with BRAVOLL® ZP and BRAVOLL® MPS in categories A, B, C and D

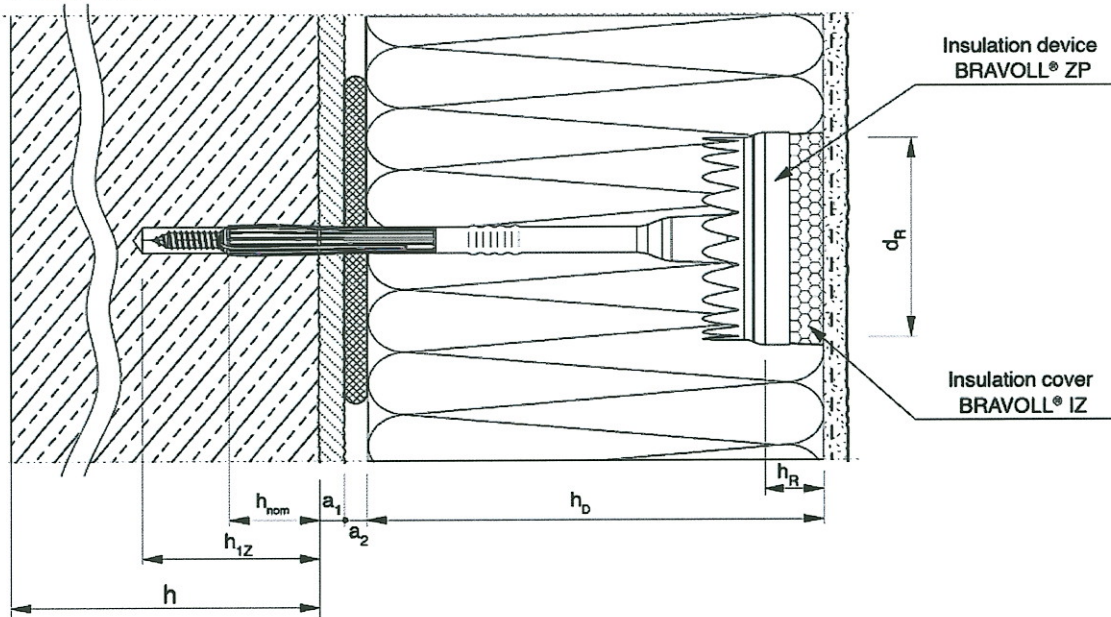

- $h_{nom}$  = overall plastic anchor embedment depth in the base material
- $h_{ef}$  = effective anchorage depth
- $h_{1p}$  = drill hole depth – surface assembly
- $h_{1z}$  = drill hole depth – countersunk assembly
- $h$  = thickness of base material
- $h_D$  = thickness of insulation material

- $h_R$  = thickness of insulation cover
- $a_1$  = thickness of equalization layer or non-load bearing coating
- $a_2$  = thickness of compound and toleration of thickness of equalization layer or non-load bearing coating
- $d_p$  = diameter of plate
- $h_R$  = diameter of insulation cover
- $L_a$  = total length of the anchor

Determination of total length of the anchor  
 $L_a \geq h_D + \min. h_{nom} + \max. a_1 + \max. a_2$

**BRAVOLL® PTH-S**

**Product description**  
 Installed conditions

**Annex A 1**

### Countersunk assembly for fixing of ETICS with BRAVOLL® ZPS in categories A, B, C and D

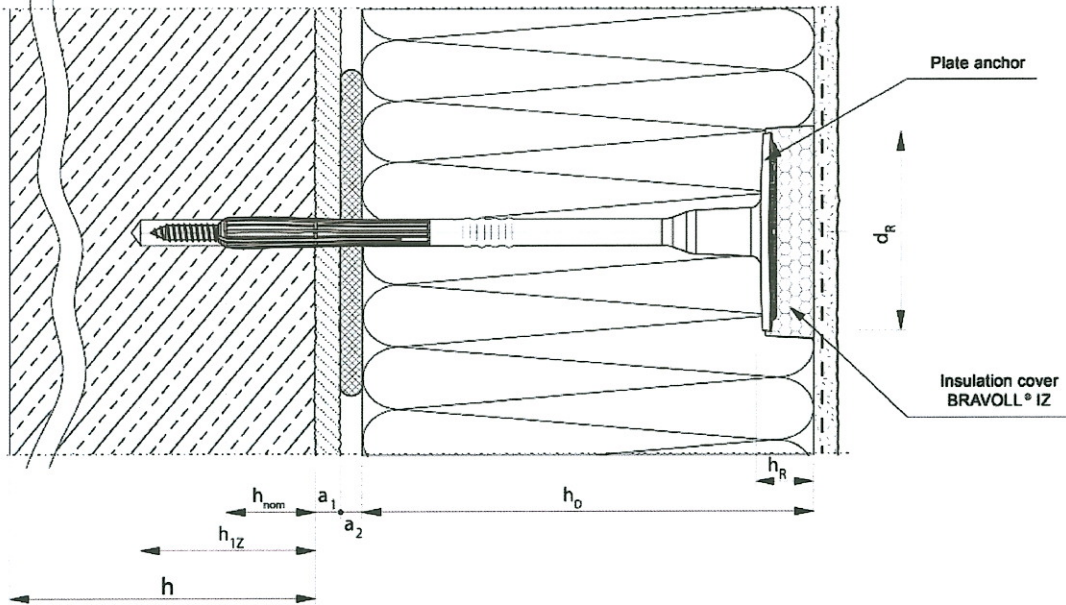

### Surface assembly for fixing of ETICS in category E

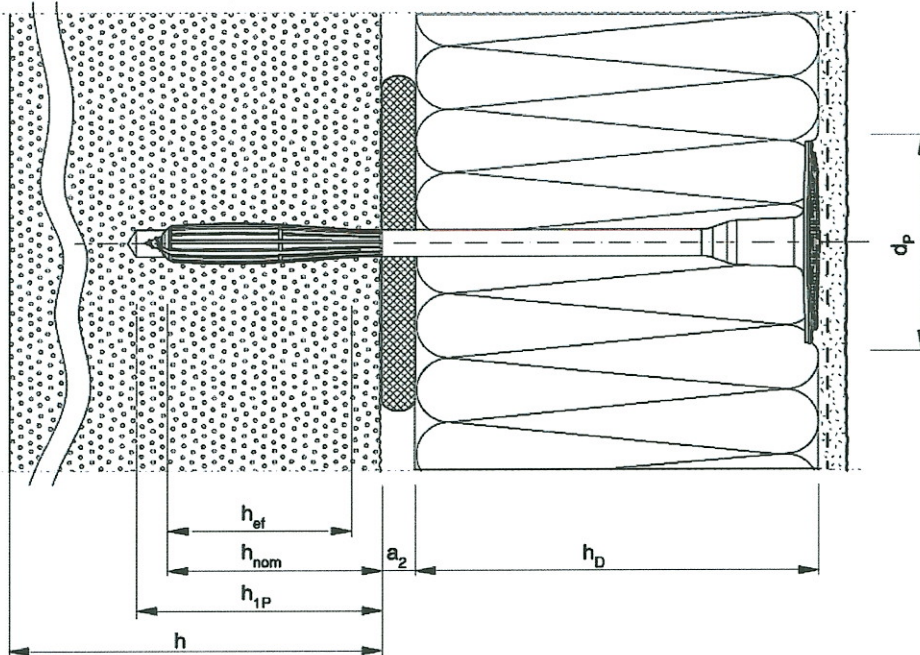

- |   |   |
|---|---|
| $h_{nom}$ = overall plastic anchor embedment depth in the base material | $h_R$ = thickness of insulation cover   |
| $h_{ef}$ = effective anchorage depth                                    | $a_1$ = thickness of equalization layer or non-load bearing coating   |
| $h_{1P}$ = drill hole depth – surface assembly                          | $a_2$ = thickness of compound and toleration of thickness of equalization layer or non-load bearing coating |
| $h_{1Z}$ = drill hole depth – countersunk assembly                      | $d_p$ = diameter of plate   |
| $h$ = thickness of base material  | $h_R$ = diameter of insulation cover  |
| $h_D$ = thickness of insulation material                                | $L_a$ = total length of the anchor  |

Determination of total length of the anchor

$$L_a \geq h_D + \min. h_{nom} + \max. a_1 + \max. a_2$$

**BRAVOLL® PTH-S**

**Product description**  
Installed conditions

**Annex A 2**

**Countersunk assembly for fixing of ETICS with BRAVOLL® ZP and BRAVOLL® MPS in category E**

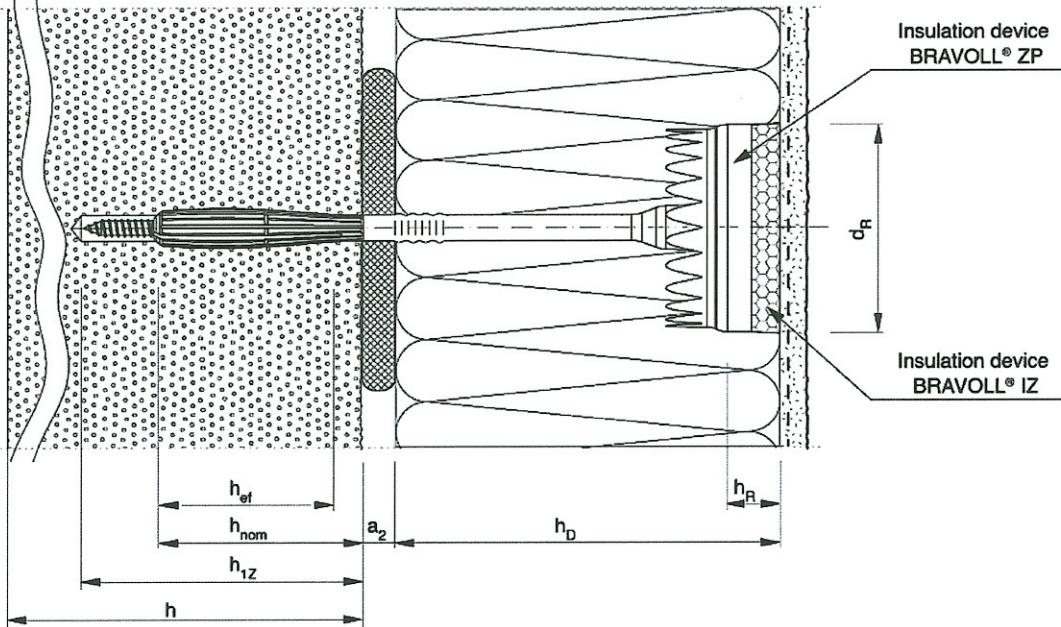

**Countersunk assembly for fixing of ETICS with BRAVOLL® ZPS in category E**

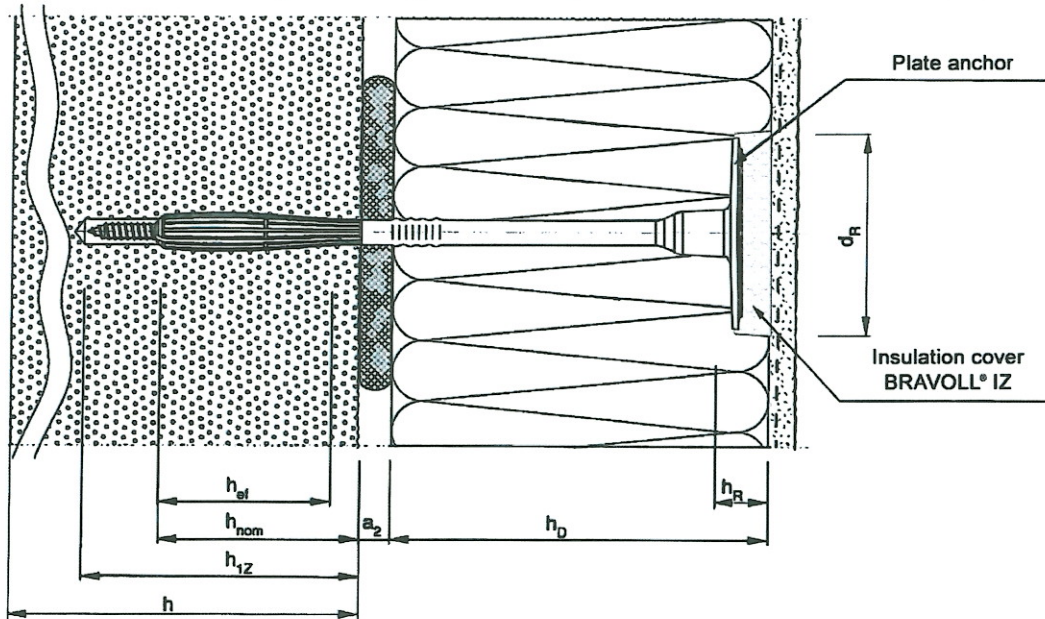

- |   |   |
|---|---|
| $h_{nom}$ = overall plastic anchor embedment depth in the base material | $h_R$ = thickness of insulation cover   |
| $h_{ef}$ = effective anchorage depth                                    | $a_1$ = thickness of equalization layer or non-load bearing coating   |
| $h_{1p}$ = drill hole depth – surface assembly                          | $a_2$ = thickness of compound and toleration of thickness of equalization layer or non-load bearing coating |
| $h_{1Z}$ = drill hole depth – countersunk assembly                      | $d_p$ = diameter of plate   |
| $h$ = thickness of base material  | $h_R$ = diameter of insulation cover  |
| $h_D$ = thickness of insulation material                                | $L_a$ = total length of the anchor  |

Determination of total length of the anchor  
 $L_a \geq h_D + \min. h_{nom} + \max. a_1 + \max. a_2$

**BRAVOLL® PTH-S**

**Product description**  
 Installed conditions

**Annex A 3**

**The assembly of profiles for fixing of ETICS in category A**

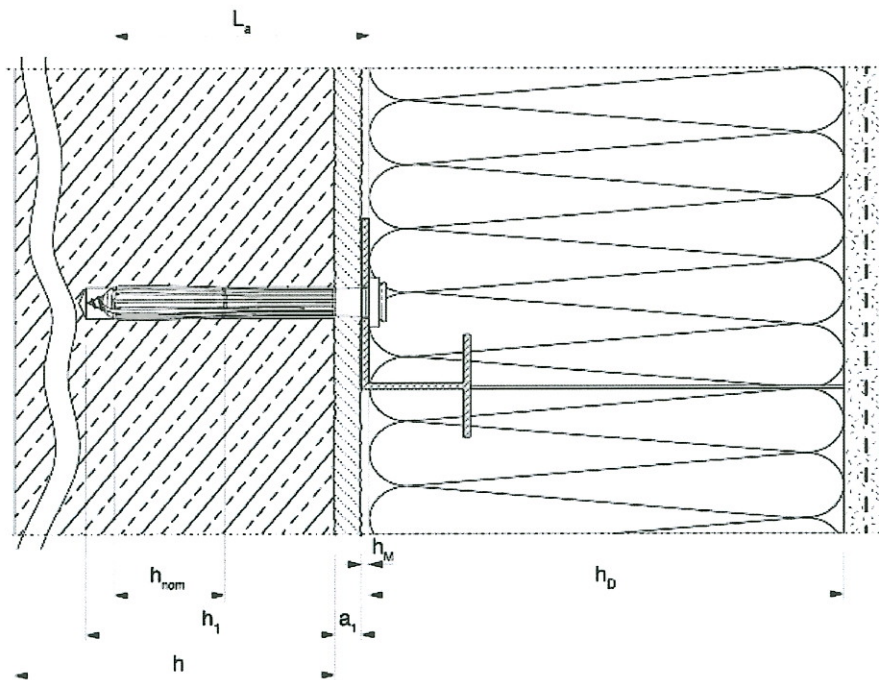

- $h_{nom}$  = overall plastic anchor embedment depth in the base material
- $h_1$  = drill hole depth
- $h$  = thickness of base material
- $h_M$  = thickness of attached material
- $L_a$  = total length of the anchor
- $a_1$  = thickness of equalization layer or non-load bearing coating

**BRAVOLL® RS-H**

**Product description**  
Installed conditions

**Annex A 4**



**BRAVOLL® PTH-S - anchor shape  $L_a$  95 – 335 mm**

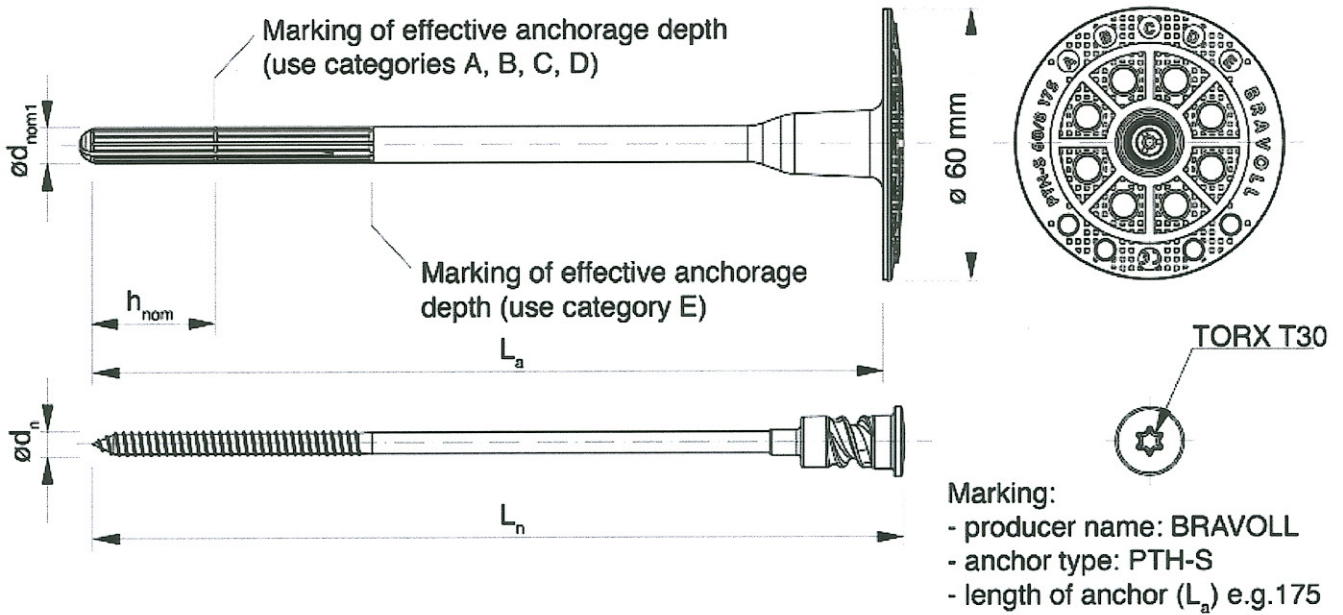

**BRAVOLL® PTH-S - anchor shape  $L_a$  355 – 555 mm**

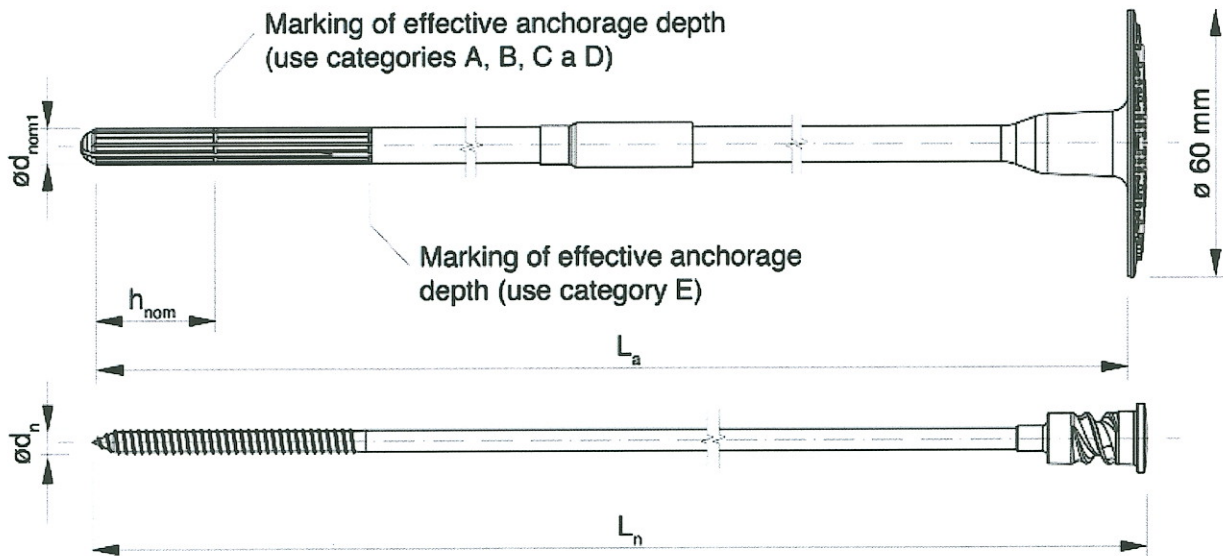

**BRAVOLL® PTH-S**

**Product description**

**Annex A 5**

**BRAVOLL® RS-H - L<sub>a</sub> 55 - 355 mm**

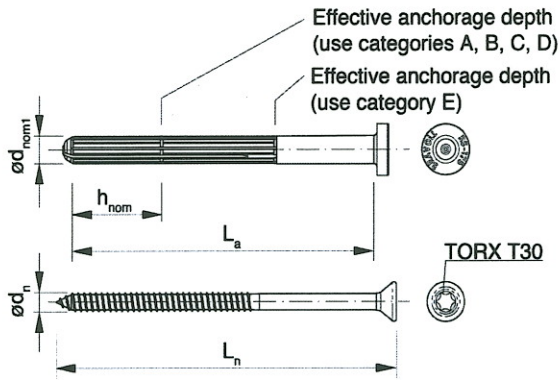

**BRAVOLL® RS-Z - L<sub>a</sub> 55 - 355 mm**

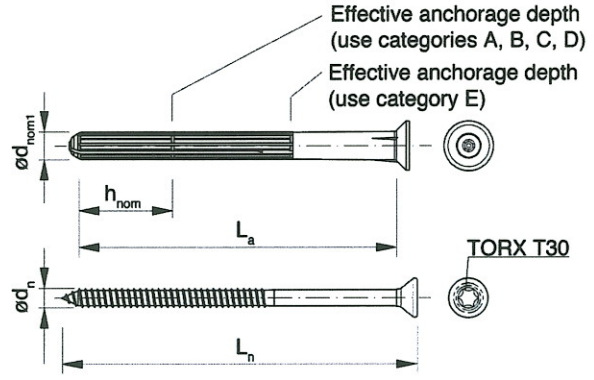

**Insulation cover BRAVOLL® IZ for EPS**

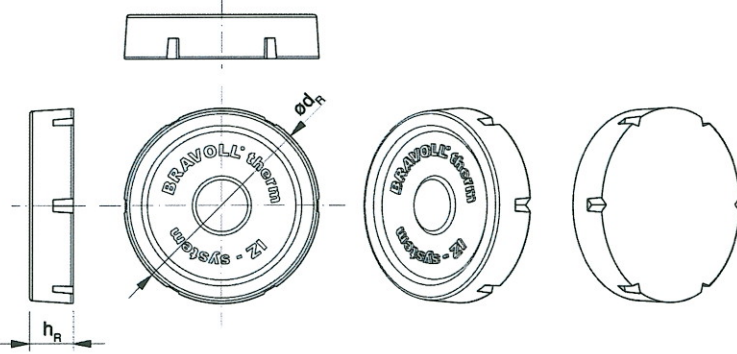

**Insulation cover BRAVOLL® IZ for MW**

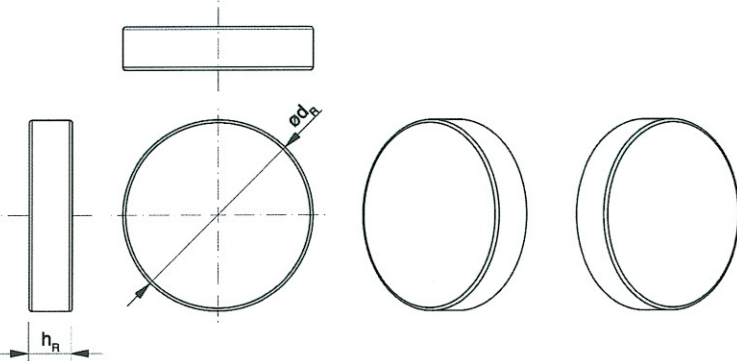

**BRAVOLL® RS-H, RS-Z, BRAVOLL® IZ**

Product description, insulation cover

**Annex A 6**

### Assembling tool BRAVOLL® ZP

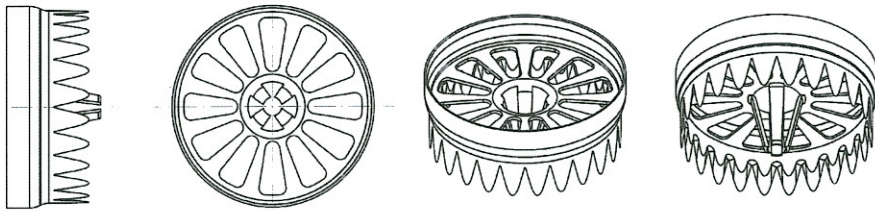

### Assembling tool BRAVOLL® MPS

- for countersunk assembly

- for surface assembly

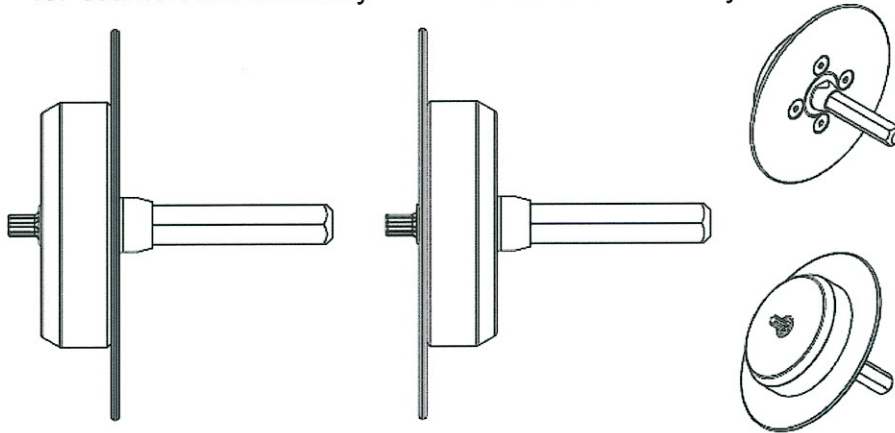

### Assembling tool BRAVOLL® ZPS

- for countersunk assembly

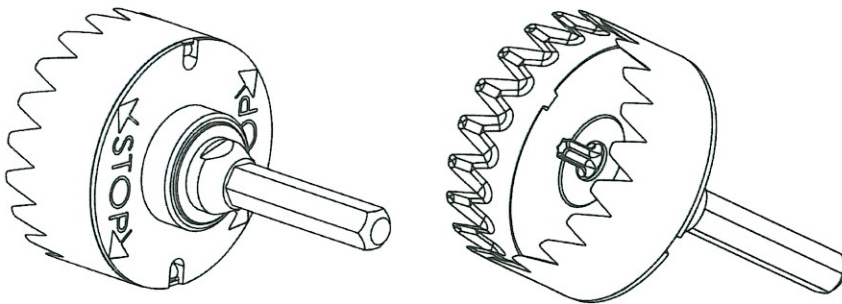

### Assembling tool BRAVOLL® ZPR

- for countersunk assembly

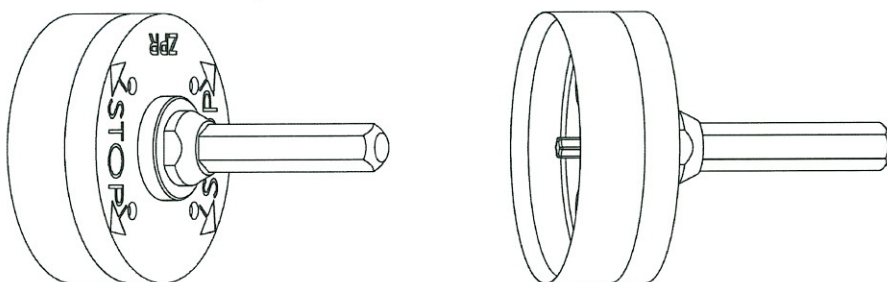

**BRAVOLL® PTH-S**

Assembling tool , Dimensions of anchor

**Annex A 7**

**Table A1: Dimensions**

Anchor type	Anchor sleeve					Expansion screw L <sub>n</sub>
	d <sub>nom1</sub>	h <sub>ef</sub>	h <sub>nom</sub>	h <sub>nom</sub>	L <sub>a</sub>	
Category of material			A, B, C, D	E		
PTH-S	8	45	25	65	95-555	103-563
RS-H	8	45	25	65	55-355	65-365
RS-Z	8	45	25	65	55-355	65-365

**Table A2: Materials**

Designation	Color	Material
Anchor sleeve PTH-S	Orange, natural	Copolymer polypropylene PP
Expansion screw PTH-S	Galvanized screw with natural colour head moulding	Steel strength class 5.8, galvanized ≥ 5µm with head of pin has plastic coating
		Stainless steel
Plate IT PTH 100 / IT PTH 140	Natural	Reinforced polyamide
Assembling tool ZP	Natural	Reinforced polyamide
Plate ZT 100 / ZT 120	Natural	Reinforced polyamide
Insulation cover IZ-EPS	White, grey	Polystyrene EPS 100
Insulation cover IZ-MW	Brown	Mineral wool HD
Anchor sleeve RS-H, RS-Z	Natural	Copolymer polypropylene PP
Expansion screw RS-H, RS-Z	Galvanized screw	Steel strength class 5.8, galvanized ≥ 5µm

**BRAVOLL® IT PTH 100**

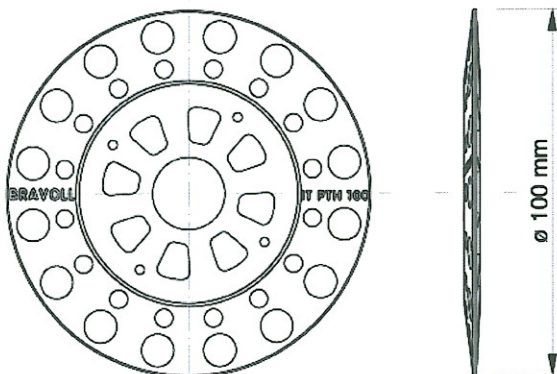

**BRAVOLL® IT PTH 140**

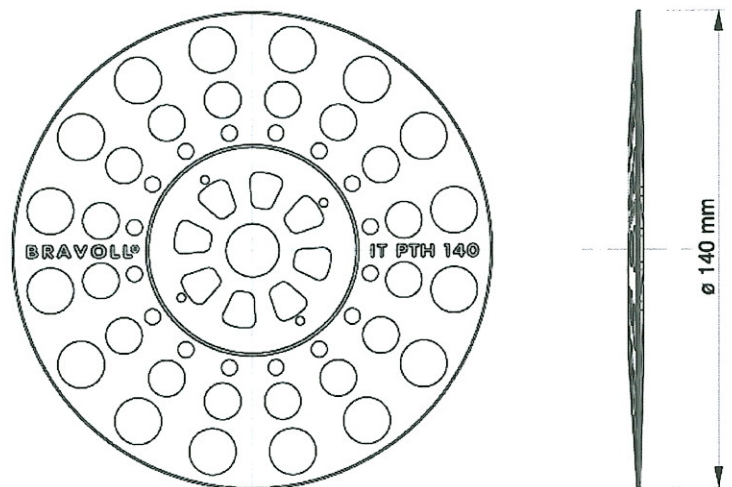

**BRAVOLL® PTH-S, BRAVOLL® IT PTH 100 , BRAVOLL® IT PTH 140**

Materials of product, Plate in combination with BRAVOLL® PTH-S for surface assembly

**Annex A 8**

**BRAVOLL® ZT 100**

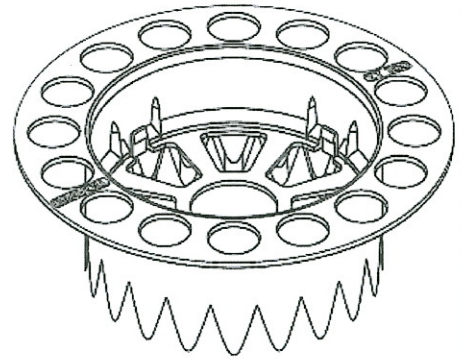
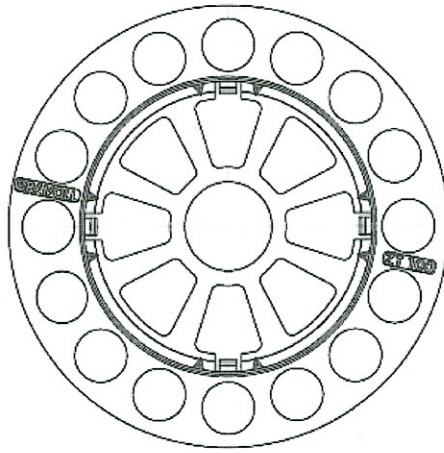
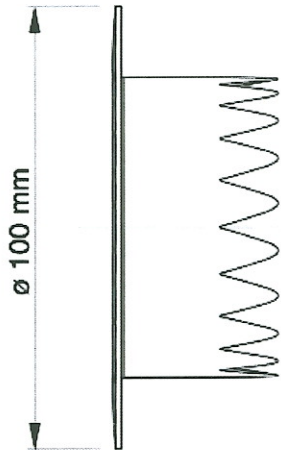

**BRAVOLL® ZT 120**

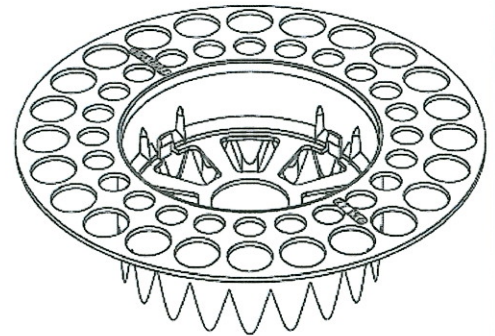
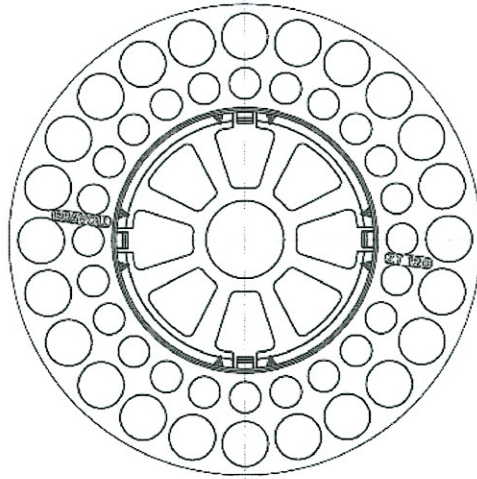
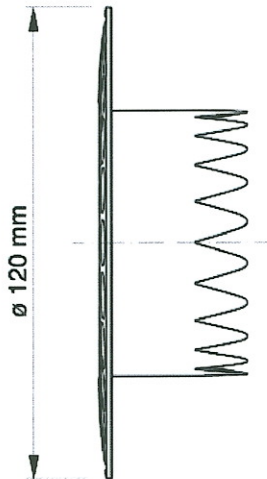

**BRAVOLL® ZT100, ZT120**

Plate ZT in combination with BRAVOLL® PTH-S for Countersunk assembly

**Annex A 9**

## Specifications of intended use

### Anchorage subject to:

- Multiple fixing for the anchorage of bonded thermal insulation composite systems (ETICS).

### Base materials

- Reinforced or unreinforced normal weight concrete (Use category A), according to Annex B3.
- Solid brick (Use category B), according to Annex B3.
- Calcium silicate solid units (Use category B), according to Annex B3.
- Vertical perforated brick (Use category C), according to Annex B3-B4.
- Vertically perforated clay bricks according to ÖNORM B 6124 (Use category C), according to Annex B3-B4.
- Lightweight aggregate concrete hollow blocks LAC (Hbl) (Use category D), according to Annex B3-B4.
- Autoclaved aerated concrete P2-400 (Use category E) according to Annex B3.
- The characteristic tension resistance of the anchor may be determined by means of job site pull-out tests carried out on the material actually used, if a characteristic resistance of the base material does not exist (for example masonry made of other solid masonry units or made of perforated clay bricks).

### Use conditions

- The anchor may only be used for transmission of wind suction loads and shall not be used for the transmission of dead loads of the thermal insulation composite system. The dead loads have to be transmitted by the bonding of the thermal insulation composite system.

### Use categories:

- The anchors PTH-S are used for the categories A, B, C, D and E.
- The anchors RS-H and RS-Z are used for the categories A, B, C, D and E.

### Design:

- The design of anchorages is carried out in compliance with EAD 330196-00-0604 for Plastic anchors made of virgin or non-virgin material for fixing of external thermal insulation composite systems with rendering.
- Verifiable calculation notes and drawings shall be prepared taking account of the loads to be anchored, the nature and strength of the base materials, the thickness of insulation and the dimensions of the anchorage as well as of the relevant tolerances.
- Proof of direct local application of load on the base material shall be delivered. The anchor shall only be used for the transmission of wind suction loads. All other loads such as dead load and restraints shall be transmitted by the adhesion of the relevant external thermal insulation composite system

**BRAVOLL® PTH-S, RS-H, RS-Z**

**Intended use**  
Installation

**Annex B 1**

**Installation:**

The fitness for use of the anchor can only be assumed if the following conditions of installation are met:

- Anchor installation carried out by appropriately qualified personnel under the supervision of the person responsible for technical matters on site.
- Use of the anchor only as supplied by the manufacturer without exchanging any component of the anchor.
- Anchor installation in accordance with the manufacturer's specifications and drawings using the tools.
- Checks before placing the anchor, to ensure that the characteristic values of the base material in which the anchor is to be placed, is identical with the values, which the characteristic loads apply for.
- Observation of the drill method (Drill holes in masonry made of perforated clay bricks, vertically perforated clay bricks and lightweight aggregate concrete hollow blocks (LAC) may only be drilled using the rotary drill. Other drilling methods may also be used if job-site tests according to Annex B 5 evaluate the influence of hammer or impact drilling.)
  - BRAVOLL® PTH-S:  $h_{nom} \geq 25 \text{ mm}$  (A, B, C, D)  
 $h_{nom} \geq 65 \text{ mm}$  (E)
  - BRAVOLL® RS-H, RS-Z:  $h_{nom} \geq 25 \text{ mm}$  (A, B, C, D)  
 $h_{nom} \geq 65 \text{ mm}$  (E)
- Placing drill holes without damaging the reinforcement
- Temperature during installation of the anchor  $\geq 0^\circ\text{C}$ .
- Exposure to UV due to solar radiation of the anchor not protected by rendering 6 weeks.

**BRAVOLL® PTH-S, RS-H, RS-Z****Intended use**  
Installation**Annex B 2**

## Types of base materials

**Table B1: Base materials**

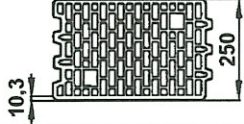
Base material	Use category	Bulk density class [kg/dm <sup>3</sup> ]	Min. compressive strength $f_c$ [N/mm <sup>2</sup> ]	General remarks	Drilling method
Concrete C12/15 according to EN 206-1	A				Hammer drilling
Concrete C16/20 – C50/60 according to EN 206-1	A				Hammer drilling
Solid clay bricks according to EN 771-1	B	$\geq 1,7$	20	Vertically perforation up to 15%	Hammer drilling
Calcium silicate solid units according to EN 771-2	B	$\geq 1,8$	12		Hammer drilling
Vertically perforated clay bricks according to EN 771-1	C	$\geq 0,7$	12	Vertically perforation more than 15% and less than 55%	Only rotary drilling
Vertically perforated clay bricks according to ÖNORM B 6124	C	$\geq 0,9$	10		Only rotary drilling
Lightweight concrete hollow block e.g. according to EN 771-3	D	$\geq 0,5$	4	see Annex B4	Only rotary drilling
Lightweight aggregate concrete hollow blocks LAC (Hbl) according to EN 1520	D	$\geq 1,2$	4		Only rotary drilling
Autoclaved aerated concrete P2-400 e.g. according to EN 771-4	E	2	$\geq 0,4$		Only rotary drilling

**BRAVOLL® PTH-S, RS-H, RS-Z**

**Intended use**  
Base materials

**Annex B 3**

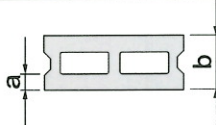
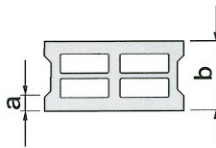
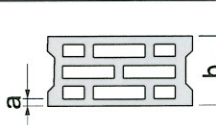
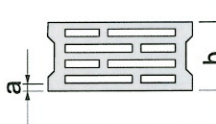
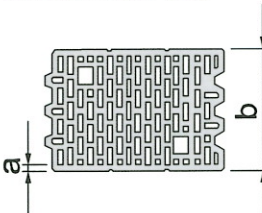
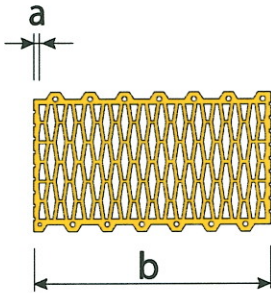

**Types of base materials**  
**Table B2:**

Geometry	Thickness of brick b [mm]	Outer web in longitudinal direction a [mm]	Anchor type	
			PTH-S	RS-H RS-Z
	175	50	●	●
	240 300	50	●	●
	175	35	●	●
	240 300 365	35	●	●
	240 300 365	30	●	●
Reference brick ÖNORM B6124 	250	10,3	●	●
	250	10,1	●	●

**BRAVOLL® PTH-S, RS-H, RS-Z**

**Intended use**  
 Base materials

**Annex B 4**

## Installation

**Table B3: Installation characteristics**

Anchor types	PTH-S		RS-H, RS-Z	
	A, B, C, D	E	A, B, C, D	E
Category of material	A, B, C, D	E	A, B, C, D	E
Nominal diameter of drill bit $d_o$ [mm]	8	8	8	8
Min. diameter of drill bit $d_{cut, min} \geq$ [mm]	8,0	8,0	8,0	8,0
Max. diameter of drill bit $d_{cut, max} \leq$ [mm]	8,45	8,45	8,45	8,45
Depth of drill hole				
- Countersunk assembly $h_{1Z} \geq$ [mm]	55	95	-	-
- Surface assembly $h_{1P} \geq$ [mm]	35	75	35	75
Overall embedment depth $h_{nom} \geq$ [mm]	25	65	25	65

**Table B4: Minimum thickness of base material, edge distance and anchor spacing**

Anchor type	Minimum thickness of base material $h$ [mm]	Minimum spacing $s_{min}$ [mm]	Minimum edge distance $c_{min}$ [mm]
PTH-S, RS-H, RS-Z	100	100	100

Scheme of distance and spacing.

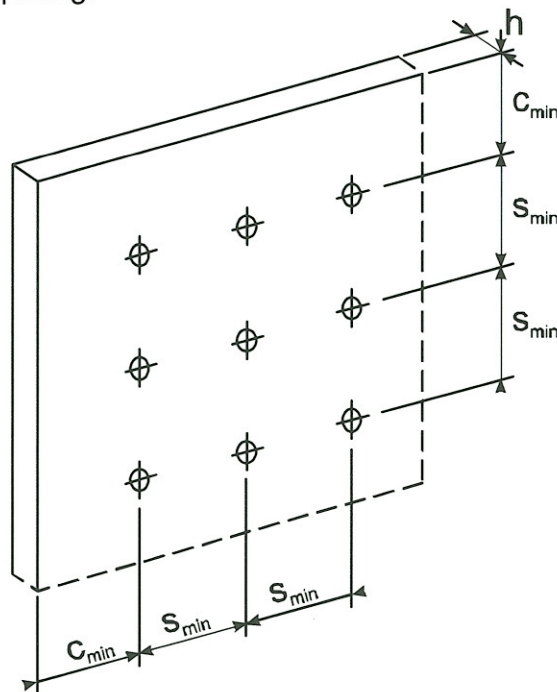

**BRAVOLL® PTH-S, RS-H, RS-Z**

**Intended use**  
Installation characteristics  
Edge and axial distances

**Annex B 5**

### Job site tests

The characteristic tension resistance of the anchor may be determined by means of job site pull-out tests carried out on the material actually used, if a characteristic resistance of the base material does not exist (for example masonry made of other solid masonry units or made of perforated clay bricks). The characteristic resistance of the anchor shall be determined by carrying out at least 15 centric tension load pull-out tests on site. These tests are also possible under the same conditions in a laboratory.

Execution and evaluation of the tests as well as the issue of the test report and the determination of the characteristic resistance should be under the responsibility of approved testing laboratories or the supervision of the person responsible for the execution of the works on site.

Number and position of the anchors to be tested shall be adapted to the relevant special conditions of the site and, for example, to be increased in the case of hidden and larger areas, such that reliable information about the characteristic resistance of the anchor in the base material in question can be derived. The tests shall take into account the most unfavourable conditions of the practical execution.

### Assembly

The anchor to be tested shall be installed (e.g. preparation of drill hole drilling tool to be used, drill bit) and the spacing and the edge distances shall be in the same way as planned for the fixing of the external thermal insulation composite system.

Depending on the drilling tool and according to ISO 5468, hard metal hammer-drill bits or hard metal percussion drill bits, respectively, shall be used. The cutting diameter shall be at the upper tolerance limit.

### Execution test

The test rig used for the pull-out test shall provide a continuous slow increase of the load, controlled by calibrated load cell. The load shall be applied perpendicularly to the surface of the base material and shall be transmitted to the anchor via a hinge. The reaction force shall be transmitted into the base material at a distance of at least 150 mm from the anchor. The load shall be increased continuously in a way, that the ultimate load is reached after about 1 minute. The load is measured when the ultimate load ( $N_1$ ) is achieved.

### Test report

The test report shall include all information necessary to assess the resistance of the tested anchor. It shall be included in the construction dossier.

The minimum data required are:

- Construction site, owner of building; date and location of the tests, air temperature; type of member (ETICS) to be fixed
- Masonry (type of brick, strength class, all dimensions of bricks, mortar group); visual assessment of masonry (flush joints, joint clearance, regularity)
- Plastic sleeve and special expansion nail, value of the cutting diameter of hard metal hammer-drill bits, measured before and after drilling
- Test rig; results of tests including the indication of value  $N_1$
- Tests carried out or supervised by; signature.

### Evaluation of test results

The characteristic resistance  $N_{Rk1}$  is derived from the measured values  $N_1$  as follows

$$N_{Rk1} = 0,6 \cdot N_1 \leq 1,5 \text{ kN}$$

$N_1$  = the mean value of the five smallest measured values at ultimate load

**BRAVOLL® PTH-S, RS-H, RS-Z**

**Intended use**  
Job site tests

**Annex B 6**

**Table C1: Characteristic resistance to tension loads for single anchor**

Base material	Use category	Bulk density class	Min. compressive strength $\beta$	PTH-S [kN]	RS-H RS-Z [kN]
		[kg/dm <sup>3</sup> ]	[N/mm <sup>2</sup> ]		
Concrete C 12/15 according to EN 206-1	A			1,5	1,5
Concrete C 16/20 –C50/60 according to EN 206-1	A			1,5	1,5
Solid clay bricks according to EN 771-1	B	≥1,7	20	1,5	1,5
Calcium silicate solid units according to EN 771-2	B	≥ 1,8	12	1,2	1,5
Vertically perforated clay bricks according to EN 771-1	C	≥ 0,5	4	1,5	1,5
Vertically perforated clay bricks according to ÖNORM B6124	C	≥ 1,2	4	1,0	1,2
Lightweight concrete hollow block e.g. according to EN 771-3	D	≥ 0,7	10	0,75	0,75
Lightweight aggregate concrete hollow blocks LAC (Hbl) according to EN 1520	D	≥ 0,9	10	0,6	0,75
Autoclaved aerated concrete P2-400 e.g. according to EN 771-4	E	≥ 0,4	2	0,6	0,6
Partial safety factor	$\gamma_M=$	2,0*			

\* in the absence of other national regulations

**Table C2: Displacement under tension loads**

Assembly  Material	Surface		Countersunk	
	Tension load $N_{Sk}$ [kN]	Displacements $\Delta\delta_N$ [mm]	Tension load $N_{Sk}$ [kN]	Displacements $\Delta\delta_N$ [mm]
C12/15 EN 206-1	0,5	<b>0,88</b>	0,5	<b>0,51</b>
C16/20 EN 206-1	0,5	<b>0,88</b>	0,5	<b>0,66</b>
C50/60 EN 206-1	0,5	<b>0,69</b>	0,5	<b>0,61</b>
Solid clay bricks EN 771-1	0,5	<b>0,73</b>	0,5	<b>0,59</b>
Vertically perforated clay bricks ÖNORM B6124	0,2	<b>0,56</b>	0,25	<b>0,36</b>
Perforated clay bricks POROTHERM P+D 44 EN 771-1	0,25	<b>0,66</b>	0,3	<b>0,56</b>
Calcium silicate solid units EN 771-2	0,4	<b>0,72</b>	0,5	<b>0,62</b>
Lightweight concrete hollow blocks EN 771-3	0,5	<b>0,68</b>	0,5	<b>0,72</b>
Lightweight aggregate concrete EN 1520 (LAC)	0,5	<b>0,85</b>	0,4	<b>0,60</b>
Autoclaved aerated concrete P2-400 according to EN 771- 4	0,25	<b>0,50</b>	0,2	<b>0,31</b>

**BRAVOLL® PTH-S, RS-H, RS-Z**

**Performances**  
Characteristic tension load  
Displacement under tension load

**Annex C 1**

**Table C3: Point thermal transmittance**

Anchor type	Insulation thickness $h_D$ [mm]	Point thermal transmittance $\chi$ [W/K]
PTH-S	60-540	0,002

**Table C4: Plate stiffness**

Anchor type	Diameter of the anchor plate [mm]	Load resistance of the anchor plate [kN]	Plate stiffness [kN/mm]
PTH-S	60	2,6	0,9

**BRAVOLL® PTH-S**

**Performances**  
Point thermal transmittance  
Plate stiffness

**Annex C 2**